





INTRODUCTION



In view of the recent amendment made in the Designs (Amendment) Rules, 2008 with effect from 17/06/2008, Publication of the matter relating to Designs is being published in the Official Journal of The Patent Office. This Journal is being published on weekly basis on every Friday covering the various proceedings on Designs as required according to the provisions of under Rule 22, 25, 27 and 39 of the Design (Amendment) Rules, 2008. All the enquiries on this Official Journal and other information as required by the public should be addressed to the Controller General of Patents, Designs & Trade Marks. Suggestions and comments are requested from all quarters so that the content can be enriched.

REGISTRATION OF DESIGNS

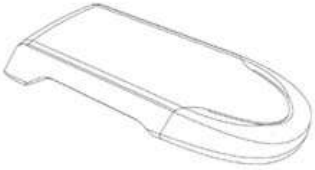
The following designs have been registered. They are now open for public inspection. In the following each entry the Date of Registration is shown. The Priority Number, Priority Date and Priority Country are also shown

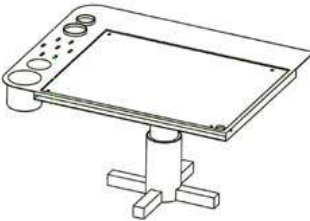
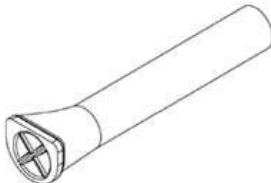

| | | | |
|---|--|----------------|--|
| DESIGN NUMBER | 331021-001 | |  |
| CLASS | 07-02 | | |
| HPCL-MITTAL ENERGY LIMITED, INOX TOWERS, PLOT NO. 17, SECTOR 16A, NOIDA, UTTAR PRADESH (U.P.), INDIA -201301 | | | |
| DATE OF REGISTRATION | 13/07/2020 | | |
| TITLE | INDUCTION COOKTOP | | |
| PRIORITY NA | | | |
| DESIGN NUMBER | 331081-001 | |  |
| CLASS | 06-05 | | |
| NILKAMAL LIMITED, PLOT NO. 77/78, STREET NO.14, M.I.D.C., ANDHERI EAST, MUMBAI 400093 | | | |
| DATE OF REGISTRATION | 14/07/2020 | | |
| TITLE | WORK CUBICLE | | |
| PRIORITY NA | | | |
| DESIGN NUMBER | 331167-001 | |  |
| CLASS | 23-01 | | |
| DEFINOX SAS, 3 RUE DES PAPETIERS, ZAC DE TABARI 2, F - 44190 CLISSON, FRANCE | | | |
| DATE OF REGISTRATION | 17/07/2020 | | |
| TITLE | CONTROL UNIT TO MONITOR AND CONTROL VALVES | | |
| PRIORITY | | | |
| PRIORITY NUMBER | DATE | COUNTRY | |
| 970043316 | 06/02/2020 | WIPO | |



| | | | |
|---|-------------------------|----------------|--|
| DESIGN NUMBER | 331185-001 | |  |
| CLASS | 14-02 | | |
| LUNU SOLUTIONS GMBH, KRONBERGER STR. 12, BERLIN (DE), GERMANY | | | |
| DATE OF REGISTRATION | 17/07/2020 | | |
| TITLE | MOBILE PAYMENT TERMINAL | | |
| PRIORITY | | | |
| PRIORITY NUMBER | DATE | COUNTRY | |
| WIPO92764 970046385 | 04/03/2020 | WIPO | |
| DESIGN NUMBER | 331200-001 | |  |
| CLASS | 01-01 | | |
| GOLDEN CHOCOLATES PVT. LTD., 10123, FIRST FLOOR, KATRA TEZAB, LIBRARY ROAD, AZAD MARKET, DELHI-110006. | | | |
| DATE OF REGISTRATION | 18/07/2020 | | |
| TITLE | LOLLIPOP | | |
| PRIORITY NA | | | |
| DESIGN NUMBER | 331264-001 | |  |
| CLASS | 23-04 | | |
| M/S GOLDMEDAL ELECTRICALS PRIVATE LIMITED A-302, KEMP PLAZA, MIND SPACE, CHINCHOLI BUNDER, OFF LINK ROAD, MALAD WEST, MUMBAI – 400 064 (INDIA) | | | |
| DATE OF REGISTRATION | 21/07/2020 | | |
| TITLE | FAN | | |
| PRIORITY NA | | | |



| | | | |
|--|--|----------------|---|
| DESIGN NUMBER | 331265-001 | |  |
| CLASS | 24-01 | | |
| 1. CHITKARA INNOVATION INCUBATOR FOUNDATION, SCO: 160-161, SECTOR -9C, MADHYA MARG, CHANDIGARH- 160009, INDIA. 2. THAKUR GURJEET SINGH, ASSISTANT DEAN & HEAD OF DEPARTMENT, CHITKARA COLLEGE OF PHARMACY, CHITKARA UNIVERSITY, PUNJAB,140401,INDIA. 3. ONKAR BEDI, ASSISTANT PROFESSOR, CHITKARA COLLEGE OF PHARMACY, CHITKARA UNIVERSITY, PUNJAB, INDIA. 4. MANVEER SINGH, CHITKARA COLLEGE OF PHARMACY, CHITKARA UNIVERSITY, PUNJAB, INDIA. . ET AL. | | | |
| DATE OF REGISTRATION | 21/07/2020 | | |
| TITLE | RODENT SURGICAL TABLE | | |
| PRIORITY NA | | |  |
| DESIGN NUMBER | 331297-001 | | |
| CLASS | 24-02 | | |
| CARL ZEISS MEDITEC AG, GÖSCHWITZER STR. 51-52, 07745 JENA, GERMANY | | | |
| DATE OF REGISTRATION | 22/07/2020 | | |
| TITLE | CUSHION FOR A PLUNGER OF A MEDICINE INJECTOR | |  |
| PRIORITY | | | |
| PRIORITY NUMBER | DATE | COUNTRY | |
| 007711684-0001 | 24/02/2020 | EUIPO | |
| DESIGN NUMBER | 331379-001 | | |
| CLASS | 06-08 | |  |
| MAINETTI (UK) LIMITED, ANNFIELD ESTATE, OXNAM ROAD, JEDBURGH, ROXBURGHSHIRE, SCOTLAND TD8 6NN, UNITED KINGDOM. | | | |
| DATE OF REGISTRATION | 27/07/2020 | | |
| TITLE | GARMENT HANGER | | |
| PRIORITY | | | |
| PRIORITY NUMBER | DATE | COUNTRY | |
| 6081825 | 28/01/2020 | U.K. | |

| | | |
|--|--------------------------------|---|
| DESIGN NUMBER | 331405-001 |  |
| CLASS | 09-01 | |
| M/S. EAGLE POLYMERS, SURVEY NO. 194 & 60, PLOT NO. 29, NEAR SAURASHTRA SOLVENT, GONDAL ROAD, KOTHARIYA, RAJKOT – 360 004 (GUJARAT) INDIA, WHOSE PARTNERS ARE (1). SHRI RAMESHBHAI RAVJIBHAI CHAVDA, (2). SMT. SHOBHANABEN RAMESHBHAI CHAVDA AND (3). SHRI KRUSHALBHAI RAMESHBHAI CHAVDA | | |
| DATE OF REGISTRATION | 27/07/2020 | |
| TITLE | BOTTLE | |
| PRIORITY NA | | |
| DESIGN NUMBER | 331410-001 |  |
| CLASS | 24-01 | |
| 1. ASHWINIRANI SR, KRISHNA INSTITUTE OF MEDICAL SCIENCES, DEEMED TO BE UNIVERSITY, NEAR DHEBEWADI ROAD, MALKAPUR, KARAD-415110, MAHARASHTRA, INDIA 2. LOKESH PATIL, KRISHNA INSTITUTE OF MEDICAL SCIENCES, DEEMED TO BE UNIVERSITY, NEAR DHEBEWADI ROAD, MALKAPUR, KARAD-415110, MAHARASHTRA, INDIA 3. GIRISH SURAGIMATH, KRISHNA INSTITUTE OF MEDICAL SCIENCES, DEEMED TO BE UNIVERSITY, NEAR DHEBEWADI ROAD, MALKAPUR, KARAD-415110, MAHARASHTRA, INDIA | | |
| DATE OF REGISTRATION | 27/07/2020 | |
| TITLE | HYDRAULIC MOUTH OPENING DEVICE | |
| PRIORITY NA | | |
| DESIGN NUMBER | 314580-001 |  |
| CLASS | 12-11 | |
| 1. VIJAY KRISHNA PRAVEEN, #224, 2ND A MAIN 13TH A CROSS, SECTOR A, YELAHANKA NEW TOWN, BANGALORE KARNATAKA-560064, INDIA 2. ALOK DAS, GULMOHAR ORCHIDS, FLAT NO.502, KHARADI, PUNE 411014, MAHARASHTRA, INDIA 3. LAKSHMISH GANGADHAR, # 75/2, RAILWAY PARALLEL ROAD, KUMARA PARK- WEST, BANGALORE 560 020, KARNATAKA, INDIA 4. NITIN RANADE, FLAT NO. C-703, PEBBLES 2 SOCIETY, SR. NO. 270, BEHIND DSK TOYOTA SHOWROOM, BAVDHAN, PUNE 411021, MAHARASHTRA, INDIA | | |
| DATE OF REGISTRATION | 05/02/2019 | |
| TITLE | A TWO-WHEELER CHASSIS | |
| PRIORITY NA | | |



| | | |
|---|---------------------------------------|--|
| DESIGN NUMBER | 331447-001 |  |
| CLASS | 26-03 | |
| SNEHA MITTAL, SITE 4, 4/16 ADARSH INDUSTRIAL AREA, SAHIBABAD, GHAZIABAD, U.P. 201010 | | |
| DATE OF REGISTRATION | 29/07/2020 | |
| TITLE | STREET LIGHT | |
| PRIORITY NA | | |
| DESIGN NUMBER | 331544-001 |  |
| CLASS | 09-03 | |
| EKA PAK GLOBAL (INDIA) PVT. LTD., 2ND FLOOR, INSPIRE WORKPLACE, #134&135, KARTHIK NAGAR, LRDE LAYOUT, DODDANEKUNDI, BANGALORE – 560037, KARNATAKA, INDIA | | |
| DATE OF REGISTRATION | 31/07/2020 | |
| TITLE | THREE COMPARTMENT FOOD PACKAGING TRAY | |
| PRIORITY NA | | |
| DESIGN NUMBER | 331577-001 |  |
| CLASS | 02-04 | |
| RELAXO FOOTWEARS LIMITED, AGGARWAL CITY SQUARE, PLOT NO. 10, MANGLAM PLACE, DISTRICT CENTRE, SECTOR – 3, ROHINI, DELHI 110085 | | |
| DATE OF REGISTRATION | 01/08/2020 | |
| TITLE | FOOTWEAR | |
| PRIORITY NA | | |



| | | |
|--|----------------|--|
| DESIGN NUMBER | 331578-001 |  |
| CLASS | 02-04 | |
| RELAXO FOOTWEARS LIMITED, AGGARWAL CITY SQUARE, PLOT NO. 10, MANGLAM PLACE, DISTRICT CENTRE, SECTOR – 3, ROHINI, DELHI 110085 | | |
| DATE OF REGISTRATION | 01/08/2020 | |
| TITLE | FOOTWEAR | |
| PRIORITY NA | | |
| DESIGN NUMBER | 331579-001 |  |
| CLASS | 02-04 | |
| RELAXO FOOTWEARS LIMITED, AGGARWAL CITY SQUARE, PLOT NO. 10, MANGLAM PLACE, DISTRICT CENTRE, SECTOR – 3, ROHINI, DELHI 110085 | | |
| DATE OF REGISTRATION | 01/08/2020 | |
| TITLE | FOOTWEAR | |
| PRIORITY NA | | |
| DESIGN NUMBER | 324281-001 |  |
| CLASS | 05-05 | |
| BIBA APPARELS PRIVATE LIMITED, NO.4, GROUND FLOOR, DELSTAR PREMISES CHS NS PATKAR MARG, HUGES ROAD, KEMPS CORNER, MUMBAI – 400036 AND CORPORATE OFFICE AT 12TH & 13TH FLOOR CAPITAL CYBERSCAPE, SECTOR-59 GOLF COURSE EXTENSION ROAD, GURUGRAM-122102 HARYANA, INDIA. | | |
| DATE OF REGISTRATION | 02/12/2019 | |
| TITLE | TEXTILE FABRIC | |
| PRIORITY NA | | |



| | | |
|--|----------------------------------|--|
| DESIGN NUMBER | 331775-001 |  |
| CLASS | 12-16 | |
| RENAULT S.A.S, 13-15 QUAI LE GALLO 92100 BOULOGNE BILLANCOURT FRANCE | | |
| DATE OF REGISTRATION | 07/08/2020 | |
| TITLE | LEFT REARVIEW MIRROR FOR VEHICLE | |
| PRIORITY NA | | |
| DESIGN NUMBER | 332150-001 |  |
| CLASS | 02-04 | |
| RELAXO FOOTWEARS LIMITED, AGGARWAL CITY SQUARE, PLOT NO. 10, MANGLAM PLACE, DISTRICT CENTRE, SECTOR – 3, ROHINI, DELHI 110085 | | |
| DATE OF REGISTRATION | 19/08/2020 | |
| TITLE | FOOTWEAR | |
| PRIORITY NA | | |
| DESIGN NUMBER | 332151-001 |  |
| CLASS | 02-04 | |
| RELAXO FOOTWEARS LIMITED, AGGARWAL CITY SQUARE, PLOT NO. 10, MANGLAM PLACE, DISTRICT CENTRE, SECTOR – 3, ROHINI, DELHI 110085 | | |
| DATE OF REGISTRATION | 19/08/2020 | |
| TITLE | FOOTWEAR | |
| PRIORITY NA | | |

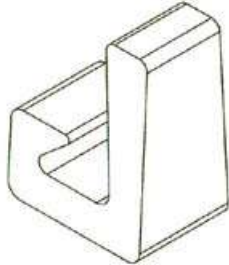

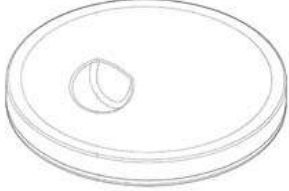
| | | | |
|--|---------------------------|----------------|--|
| DESIGN NUMBER | 332231-001 | |  |
| CLASS | 23-04 | | |
| BAJAJ ELECTRICALS LIMITED, 45/47, VEER NARIMAN ROAD, FORT, MUMBAI, MAHARASHTRA - 400001. | | | |
| DATE OF REGISTRATION | 22/08/2020 | | |
| TITLE | FAN | | |
| PRIORITY NA | | | |
| DESIGN NUMBER | 332302-001 | |  |
| CLASS | 13-03 | | |
| GEEP INDUSTRIES (I) PVT. LTD., CENTRUM, #1201, 12TH FLOOR, OPP.RAILA DEVI LAKE, NEXT TO ASM INSTITUTE OF COMPUTER MANAGEMENT, NEAR SATKAR GRANDE HOTEL, WAGLE ESTATE, THANE (W) - 400 604, MAHARASHTRA, INDIA | | | |
| DATE OF REGISTRATION | 25/08/2020 | | |
| TITLE | MULTI PLUG EXTENSION CORD | | |
| PRIORITY NA | | | |
| DESIGN NUMBER | 325276-001 | |  |
| CLASS | 14-04 | | |
| FACEBOOK TECHNOLOGIES, LLC, 1601 WILLOW ROAD, MENLO PARK, CALIFORNIA 94025, UNITED STATES OF AMERICA | | | |
| DATE OF REGISTRATION | 31/12/2019 | | |
| TITLE | DISPLAY DEVICE | | |
| PRIORITY | | | |
| PRIORITY NUMBER | DATE | COUNTRY | |
| 29/698,234 | 15/07/2019 | U.S.A. | |

| | | |
|---|-------------|--|
| DESIGN NUMBER | 333082-001 |  |
| CLASS | 23-02 | |
| JYOTI INDIA KITCHENSINK PRIVATE LIMITED, 701, ROYAL GRACE, LMTV MARG NO 2, OPP PUNJAB NATIONAL BANK, DADAR (EAST), MUMBAI 400 014. | | |
| DATE OF REGISTRATION | 10/09/2020 | |
| TITLE | STRAINER | |
| PRIORITY NA | | |
| DESIGN NUMBER | 333280-001 |  |
| CLASS | 09-03 | |
| JEWEL PLAST, PLOT NO.361/8, SHREE GANESH INDUSTRIAL ESTATE, KACHIGAM, DAMAN- 396 210, WHOSE PROPRIETORS ARE SHRI. BASANT J. BAFNA AND SMT. DAKSHA B. BAFNA | | |
| DATE OF REGISTRATION | 16/09/2020 | |
| TITLE | SOAP CASE | |
| PRIORITY NA | | |
| DESIGN NUMBER | 333298-001 |  |
| CLASS | 23-99 | |
| BRILLOCA LIMITED, 2, RED CROSS PLACE, KOLKATA-700001 | | |
| DATE OF REGISTRATION | 17/09/2020 | |
| TITLE | URINAL EDGE | |
| PRIORITY NA | | |

| | | |
|---|-----------------------------------|--|
| DESIGN NUMBER | 340414-001 |  |
| CLASS | 16-04 | |
| TECHNOCULTURE RESEARCH PRIVATE LIMITED, F. NO. 303 B NUTAN TOWER KBAGH, KARBIGAHIYA, PATNA - 800020, BIHAR, INDIA | | |
| DATE OF REGISTRATION | 09/03/2021 | |
| TITLE | PHOTOLITHOGRAPHY INSTRUMENT-4S. | |
| PRIORITY NA | | |
| DESIGN NUMBER | 333705-001 |  |
| CLASS | 15-02 | |
| CROMPTON GREAVES CONSUMER ELECTRICALS LIMITED, EQUINOX BUSINESS PARK, TOWER 3, 1ST FLOOR, EAST WING, LBS MARG, KURLA (WEST), MUMBAI 400 070, MAHARASHTRA, INDIA. | | |
| DATE OF REGISTRATION | 28/09/2020 | |
| TITLE | PUMP | |
| PRIORITY NA | | |
| DESIGN NUMBER | 327345-001 |  |
| CLASS | 15-99 | |
| CARBORUNDUM UNIVERSAL LIMITED, PARRY HOUSE- 6TH FLOOR, 43 MOORE STREET, CHENNAI 600001, INDIA | | |
| DATE OF REGISTRATION | 19/02/2020 | |
| TITLE | CERAMIC J-TILE FOR AIR CLASSIFIER | |
| PRIORITY NA | | |

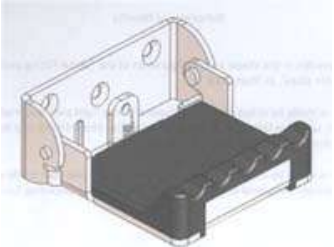

| | | | |
|---|---------------------|----------------|--|
| DESIGN NUMBER | 333997-001 | |  |
| CLASS | 28-03 | | |
| THE GILLETTE COMPANY LLC, ONE GILLETTE PARK, BOSTON, MASSACHUSETTS 02127, UNITED STATES OF AMERICA | | | |
| DATE OF REGISTRATION | 07/10/2020 | | |
| TITLE | SHAVING RAZOR STAND | | |
| PRIORITY | | | |
| PRIORITY NUMBER | DATE | COUNTRY | |
| 29/730908 | 09/04/2020 | U.S.A. | |
| DESIGN NUMBER | 334142-001 | |  |
| CLASS | 02-02 | | |
| GRAPHIC ERA HILL UNIVERSITY, 510, SOCIETY AREA, CLEMENT TOWN, DEHRADUN, 248002, UTTARAKHAND, INDIA | | | |
| DATE OF REGISTRATION | 10/10/2020 | | |
| TITLE | WAIST COAT | | |
| PRIORITY NA | | | |
| DESIGN NUMBER | 340776-001 | |  |
| CLASS | 02-02 | | |
| HOUSE OF ANITA DONGRE PRIVATE LIMITED, PLOT NO. R 847/1/1, TTC INDUSTRIAL AREA, MIDC, RABALE, NAVI MUMBAI, MAHARASHTRA-400701, INDIA | | | |
| DATE OF REGISTRATION | 16/03/2021 | | |
| TITLE | GARMENT SET | | |
| PRIORITY NA | | | |

| | | |
|--|--|--|
| DESIGN NUMBER | 340836-001 |  |
| CLASS | 03-01 | |
| SOMA BISWAS, JACK AND JILL, 754, SAHID KHUDIRAM BOSE SARANI, NORTH 24 PARGANAS, DUM DUM, KOLKATA - 700030, WEST BENGAL, INDIA | | |
| DATE OF REGISTRATION | 17/03/2021 | |
| TITLE | BACKPACK | |
| PRIORITY NA | | |
| DESIGN NUMBER | 334175-001 |  |
| CLASS | 08-06 | |
| GODREJ & BOYCE MFG. CO. LTD., PLANT 12 CORPORATE ADVISORY PIROJSHANAGAR, VIKHROLI, MUMBAI-400079, MAHARASHTRA, INDIA | | |
| DATE OF REGISTRATION | 12/10/2020 | |
| TITLE | HANDLE | |
| PRIORITY NA | | |
| DESIGN NUMBER | 334251-001 |  |
| CLASS | 08-09 | |
| DORMAKABA INDIA PRIVATE LIMITED, MAHINDRA WORLD CITY, PLOT NO.48/3, 8TH AVENUE, ANJUR VILLAGE, CHENGALPATTU TALUK, KANCHEEPURAM DISTRICT - 603002, TAMIL NADU | | |
| DATE OF REGISTRATION | 14/10/2020 | |
| TITLE | METAL FITTING AND MOUNTING FOR DOORS -FOOT PLATE | |
| PRIORITY NA | | |

| | | | |
|--|--------------------|-------------------|--|
| DESIGN NUMBER | 318311-001 | |  |
| CLASS | 14-03 | | |
| SAMSUNG ELECTRONICS CO., LTD., 129, SAMSUNG-RO, YEONGTONG-GU, SUWON-SI, GYEONGGI-DO, 16677, REPUBLIC OF KOREA | | | |
| DATE OF REGISTRATION | 31/05/2019 | | |
| TITLE | MOBILE PHONE | | |
| PRIORITY | | | |
| PRIORITY NUMBER | DATE | COUNTRY | |
| 30-2018-0059241 | 14/12/2018 | REPUBLIC OF KOREA | |
| DESIGN NUMBER | 334425-001 | |  |
| CLASS | 17-03 | | |
| INDIAN INSTITUTE OF TECHNOLOGY BOMBAY, POWAI, MUMBAI 400 076, STATE OF MAHARASHTRA, INDIA | | | |
| DATE OF REGISTRATION | 19/10/2020 | | |
| TITLE | MUSICAL INSTRUMENT | | |
| PRIORITY NA | | | |
| DESIGN NUMBER | 334454-001 | |  |
| CLASS | 09-03 | | |
| RUCHIKA D. BHANGDIYA, C-1002, RAHEJA VISTAS, RAHEJA VIHAR, CHANDIWALI, MUMBAI MAHARASHTRA - 400072 | | | |
| DATE OF REGISTRATION | 20/10/2020 | | |
| TITLE | CHOCOLATE BOX | | |
| PRIORITY NA | | | |

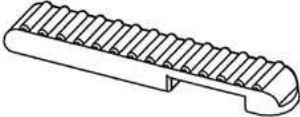
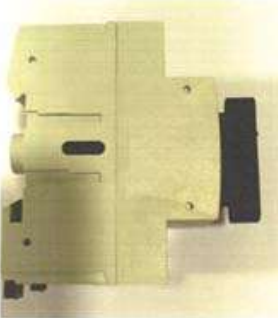

| | | |
|--|------------------|--|
| DESIGN NUMBER | 334505-001 |  |
| CLASS | 26-05 | |
| CROMPTON GREAVES CONSUMER ELECTRICALS LIMITED, EQUINOX BUSINESS PARK, TOWER 3, 1ST FLOOR, EAST WING, LBS MARG, KURLA (WEST), MUMBAI 400 070, MAHARASHTRA, INDIA | | |
| DATE OF REGISTRATION | 21/10/2020 | |
| TITLE | STREET LIGHT | |
| PRIORITY NA | | |
| DESIGN NUMBER | 334639-001 |  |
| CLASS | 11-02 | |
| TYAGI PLASTICS, 1536, MIE, PART-B, BAHADURGARH-124507, DISTT. JHAJJAR, HARYANA, INDIA | | |
| DATE OF REGISTRATION | 26/10/2020 | |
| TITLE | PLANTER | |
| PRIORITY NA | | |
| DESIGN NUMBER | 334666-001 |  |
| CLASS | 02-04 | |
| M/S. EUPHORIC INNOVATIONS PVT. LTD, VII/3I3H, NH-17, KOLATHARA P.O, KOZHIKODE, KERALA, PIN-673655, INDIA | | |
| DATE OF REGISTRATION | 27/10/2020 | |
| TITLE | SOLE OF FOOTWEAR | |
| PRIORITY NA | | |

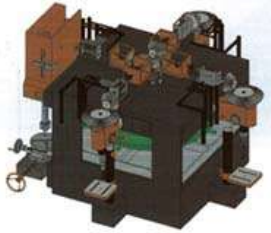

| | | | |
|--|-----------------------------------|----------------|---|
| DESIGN NUMBER | 334741-001 | |  |
| CLASS | 31-00 | | |
| HINDVIJAY APPLIANCES PVT. LTD., SECTOR NO. 3, S. NO.66., H. NO. 5/6, BILAL PADA, GAUKIWARE, VASAI (EAST) DIST PALGHAR - 401208, MAHARASHTRA, INDIA | | | |
| DATE OF REGISTRATION | 29/10/2020 | | |
| TITLE | BODY OF MIXER GRINDER | | |
| PRIORITY NA | | |  |
| DESIGN NUMBER | 318983-001 | | |
| CLASS | 06-08 | | |
| ERUM EXPORT PRIVATE LIMITED, C-3, HOSIERY COMPLEX, PHASE II, NOIDA-201 301 (UP) | | | |
| DATE OF REGISTRATION | 22/06/2019 | | |
| TITLE | ANTI-SLIP RUBBER GRIP FOR HANGERS | | |
| PRIORITY | | | |
| PRIORITY NUMBER | DATE | COUNTRY | |
| 006367785-0004 | 02/04/2019 | EUIPO | |
| DESIGN NUMBER | 334992-001 | |  |
| CLASS | 13-03 | | |
| NOVATEUR ELECTRICAL & DIGITAL SYSTEMS PRIVATE LIMITED, 61/62, 6TH FLOOR, KALPATARU SQUARE, KONDIVITA ROAD, OFF. ANDHERI – KURLA ROAD, ANDHERI (EAST), MUMBAI – 400 059. | | | |
| DATE OF REGISTRATION | 06/11/2020 | | |
| TITLE | SWITCH | | |
| PRIORITY NA | | | |

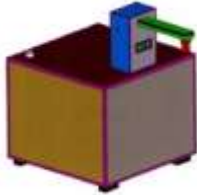
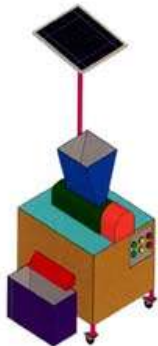

| | | |
|--|---------------------------|---|
| DESIGN NUMBER | 328488-001 |  |
| CLASS | 02-02 | |
| ASHOK GONDALIA, 63, SHREE DARSHAN ROW HOUSE BEHIND SAI KRUPA RESIDENCY, KARADVA GAM, DINDOLI, SURAT-394210, GUJARAT, INDIA. | | |
| DATE OF REGISTRATION | 20/03/2020 | |
| TITLE | SAREE | |
| PRIORITY NA | | |
| DESIGN NUMBER | 335116-001 |  |
| CLASS | 26-04 | |
| MALATHI DAMERA, 5 N ALDER CT, HAWTHORNWOODS IL 60047 | | |
| DATE OF REGISTRATION | 10/11/2020 | |
| TITLE | LED STRING LIGHT | |
| PRIORITY NA | | |
| DESIGN NUMBER | 328746-001 |  |
| CLASS | 15-09 | |
| 1.DR SEERAM SRINIVASA RAO, DEPARTMENT OF MECHANICAL ENGINEERING, KONERULAKSHMAIAH EDUCATION FOUNDATION, GREEN FIELDS, VADDESARAM, GUNTUR, ANDHRA PRADESH-522502, INDIA 2. KANDULA LOKESH SAI REDDY, DEPARTMENT OF MECHANICAL ENGINEERING, KONERULAKSHMAIAH EDUCATION FOUNDATION, GREEN FIELDS, VADDESARAM, GUNTUR, ANDHRA PRADESH-522502, INDIA 3. PEDDINTI NITHYA SREETEJO SATHWIK, DEPARTMENT OF MECHANICAL ENGINEERING, KONERULAKSHMAIAH EDUCATION FOUNDATION, GREEN FIELDS, VADDESARAM, GUNTUR, ANDHRA PRADESH-522502, INDIA 4. KOTHA SUJAN SURYA, DEPARTMENT OF MECHANICAL ENGINEERING, KONERULAKSHMAIAH EDUCATION FOUNDATION, GREEN FIELDS, VADDESARAM, GUNTUR, ANDHRA PRADESH-522502, INDIA , ET AL. | | |
| DATE OF REGISTRATION | 03/04/2020 | |
| TITLE | MULTIPURPOSE MACHINE TOOL | |
| PRIORITY NA | | |

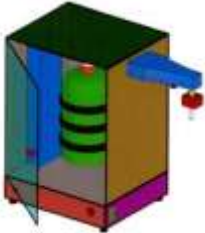

| | | | |
|---|-----------------|----------------|--|
| DESIGN NUMBER | 328753-001 | |  |
| CLASS | 12-05 | | |
| W. GESSMANN GMBH, EPPINGER STR. 221 - 74211 LEINGARTEN, GERMANY. | | | |
| DATE OF REGISTRATION | 06/04/2020 | | |
| TITLE | TRANSPORT ROBOT | | |
| PRIORITY | | | |
| PRIORITY NUMBER | DATE | COUNTRY | |
| 006986741 | 07/10/2019 | EUIPO | |
| DESIGN NUMBER | 335366-001 | |  |
| CLASS | 09-01 | | |
| ARPIT MUNANI, 111, MANISH INDUSTRIAL ESTATE NO.2, NAVGHAR ROAD, VASAI EAST, PALGHAR - 401208 | | | |
| DATE OF REGISTRATION | 19/11/2020 | | |
| TITLE | BOTTLE | | |
| PRIORITY NA | | | |
| DESIGN NUMBER | 335404-001 | | |
| CLASS | 09-03 | | |
| M/S. AROCHEM RATLAM PVT. LTD, 454, RAM BAGH, RATLAM – 457001, (M.P.) | | | |
| DATE OF REGISTRATION | 20/11/2020 | |  |
| TITLE | BOX | | |
| PRIORITY NA | | | |

| | | |
|---|---|--|
| DESIGN NUMBER | 341876-001 |  |
| CLASS | 08-05 | |
| GOVINDA AGRO TECH LTD, NIRMALA AGYARAM DEVI SQUARE, GANESHPETH NAGPUR-440018, INDIA, WHOSE DIRECTOR IS MEENA G. GANDHI | | |
| DATE OF REGISTRATION | 05/04/2021 | |
| TITLE | SPRAYER PUMP | |
| PRIORITY NA | | |
| DESIGN NUMBER | 342013-001 |  |
| CLASS | 23-04 | |
| KANTA DEVI BABULAL JAIN, ROOM NO. B - 223, S. M. CHAWL, DHARAVI MAIN ROAD, NEAR OLD POLICE STATION, DHARAVI, MUMBAI - 400 017, MAHARASHTRA, INDIA | | |
| DATE OF REGISTRATION | 07/04/2021 | |
| TITLE | TOWER FAN | |
| PRIORITY NA | | |
| DESIGN NUMBER | 342039-001 |  |
| CLASS | 24-01 | |
| 1. DR. S. MALARKKAN, PRINCIPAL, DEPARTMENT OF ELECTRONICS AND COMMUNICATION ENGINEERING, MANAKULA VINAYAGAR INSTITUTE OF TECHNOLOGY, KALITHEERTHALKUPPAM, PUDUCHERRY - 605107, INDIA 2. DR. R. VALLI, PROFESSOR AND R&D COORDINATOR, DEPARTMENT OF ELECTRONICS AND COMMUNICATION ENGINEERING, MANAKULA VINAYAGAR INSTITUTE OF TECHNOLOGY, KALITHEERTHALKUPPAM, PUDUCHERRY - 605107, INDIA 3. DR. N POONGUZHALI, ASSOCIATE PROFESSOR, DEPARTMENT OF COMPUTER SCIENCE ENGINEERING, MANAKULA VINAYAGAR INSTITUTE OF TECHNOLOGY, KALITHEERTHALKUPPAM, PUDUCHERRY - 605107, INDIA 4. DR. S. ARUNMOZHI, PROFESSOR & HEAD, DEPARTMENT OF ELECTRONICS AND COMMUNICATION ENGINEERING, MANAKULA VINAYAGAR INSTITUTE OF TECHNOLOGY, KALITHEERTHALKUPPAM, PUDUCHERRY - 605107, INDIA | | |
| DATE OF REGISTRATION | 07/04/2021 | |
| TITLE | PORTABLE PHYSIOTHERAPY EQUIPMENT WITH AUTOMATIC HEIGHT ADJUSTABLE PARALLEL WALKING BARS | |
| PRIORITY NA | | |

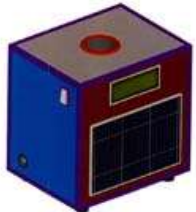

| | | |
|---|--|---|
| DESIGN NUMBER | 342040-001 |  |
| CLASS | 23-01 | |
| 1.DR. N POONGUZHALL, ASSOCIATE PROFESSOR, DEPARTMENT OF COMPUTER SCIENCE ENGINEERING, MANAKULA VINAYAGAR INSTITUTE OF TECHNOLOGY, KALITHEERTHALKUPPAM, PUDUCHERRY - 605107, INDIA 2. V. RAJESH, ASSISTANT PROFESSOR, DEPARTMENT OF ELECTRONICS AND COMMUNICATION ENGINEERING, MANAKULA VINAYAGAR INSTITUTE OF TECHNOLOGY, KALITHEERTHALKUPPAM, PUDUCHERRY - 605107, INDIA 3. DR. S. MALARKKAN, PRINCIPAL, DEPARTMENT OF ELECTRONICS AND COMMUNICATION ENGINEERING, MANAKULA VINAYAGAR INSTITUTE OF TECHNOLOGY, KALITHEERTHALKUPPAM, PUDUCHERRY - 605107, INDIA 4. DR. R. VALLI, PROFESSOR AND R&D COORDINATOR, DEPARTMENT OF ELECTRONICS AND COMMUNICATION ENGINEERING, MANAKULA VINAYAGAR INSTITUTE OF TECHNOLOGY, KALITHEERTHALKUPPAM, PUDUCHERRY - 605107, INDIA | | |
| DATE OF REGISTRATION | 07/04/2021 | |
| TITLE | AUTOMATIC WATER DISPENSER WITH WATER STORAGE TANK | |
| PRIORITY NA | | |
| DESIGN NUMBER | 342042-002 |  |
| CLASS | 15-03 | |
| 1.R. PRIYA, ASSISTANT PROFESSOR, DEPARTMENT OF ELECTRICAL AND ELECTRONICS ENGINEERING, MANAKULA VINAYAGAR INSTITUTE OF TECHNOLOGY, KALITHEERTHALKUPPAM, PUDUCHERRY - 605107, INDIA 2. DR. R. VALLI, PROFESSOR AND R&D COORDINATOR, DEPARTMENT OF ELECTRONICS AND COMMUNICATION ENGINEERING, MANAKULA VINAYAGAR INSTITUTE OF TECHNOLOGY, KALITHEERTHALKUPPAM, PUDUCHERRY - 605107, INDIA 3. P. L. SANTHANA KRISHNAN, ASSISTANT PROFESSOR, DEPARTMENT OF ELECTRICAL AND ELECTRONICS ENGINEERING, MANAKULA VINAYAGAR INSTITUTE OF TECHNOLOGY, KALITHEERTHALKUPPAM, PUDUCHERRY - 605107, INDIA 4. V. RAJESH, ASSISTANT PROFESSOR, DEPARTMENT OF ELECTRONICS AND COMMUNICATION ENGINEERING, MANAKULA VINAYAGAR INSTITUTE OF TECHNOLOGY, KALITHEERTHALKUPPAM, PUDUCHERRY - 605107, INDIA | | |
| DATE OF REGISTRATION | 07/04/2021 | |
| TITLE | PORTABLE SOLAR POWERED PADDY THRESHER AND DEHUSKER | |
| PRIORITY NA | | |
| DESIGN NUMBER | 342044-001 |  |
| CLASS | 24-01 | |
| 1.DR. G.V. MANOHARAN, PROFESSOR, GENERAL SURGERY, SRI MANAKULA VINAYAGAR MEDICAL COLLEGE AND HOSPITAL, KALITHEERTHALKUPPAM, PUDUCHERRY - 605107, INDIA 2. DR. M. ANTO, PROFESSOR, GENERAL SURGERY, SRI MANAKULA VINAYAGAR MEDICAL COLLEGE AND HOSPITAL, KALITHEERTHALKUPPAM, PUDUCHERRY - 605107, KALITHEERTHALKUPPAM, PUDUCHERRY - 605107, INDIA 4 INDIA 3. DR. M. RAJAVEL, ASSOCIATE PROFESSOR, GENERAL SURGERY, SRI MANAKULA VINAYAGAR MEDICAL COLLEGE AND HOSPITAL., DR. ARULSELVAN. A, ASSISTANT PROFESSOR, GENERAL SURGERY, SRI MANAKULA VINAYAGAR MEDICAL COLLEGE AND HOSPITAL, KALITHEERTHALKUPPAM, PUDUCHERRY - 605107, INDIA | | |
| DATE OF REGISTRATION | 07/04/2021 | |
| TITLE | DIGITAL SINGLE SLOTTED BLOOD GEL CARD WARMER | |
| PRIORITY NA | | |

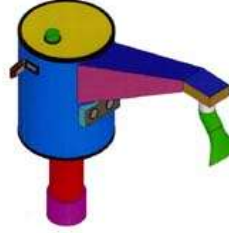
| | | |
|--|---|---|
| DESIGN NUMBER | 342045-001 |  |
| CLASS | 24-01 | |
| 1.DR. MANGANI MANGALAVALLI. S, ASSISTANT PROFESSOR., PHYSIOLOGY, SRI MANAKULA VINAYAGAR MEDICAL COLLEGE AND HOSPITAL, KALITHEERTHALKUPPAM, PUDUCHERRY - 605107, INDIA 2. DR. VINOTH. K, ASSOCIATE PROFESSOR., PHYCHIATRY, SRI MANAKULA VINAYAGAR MEDICAL COLLEGE AND HOSPITAL, KALITHEERTHALKUPPAM, PUDUCHERRY - 605107, INDIA 3. DR. VINAYAGAMOORTHY. V, ASSOCIATE PROFESSOR., COMMUNITY MEDICINE, SRI MANAKULA VINAYAGAR MEDICAL COLLEGE AND HOSPITAL, KALITHEERTHALKUPPAM, PUDUCHERRY - 605107, INDIA 4. MS. RAJARAJESHWARI. R, ASSISTANT PROFESSOR., BIOCHEMISTRY, SRI MANAKULA VINAYAGAR MEDICAL COLLEGE AND HOSPITAL, KALITHEERTHALKUPPAM, PUDUCHERRY - 605107, INDIA | | |
| DATE OF REGISTRATION | 07/04/2021 | |
| TITLE | SOLAR OPERABLE CHEMICAL DISPENSING SYSTEM FOR URINE ANALYSIS | |
| PRIORITY NA | | |
| DESIGN NUMBER | 342046-001 |  |
| CLASS | 24-01 | |
| 1.DR. NALLAMUTHU. P, PROFESSOR, OPHTHALMOLOGY, SRI MANAKULA VINAYAGAR MEDICAL COLLEGE AND HOSPITAL, KALITHEERTHALKUPPAM, PUDUCHERRY - 605107, INDIA 2. DR. JAYASREE. M, PROFESSOR, OBG, SRI MANAKULA VINAYAGAR MEDICAL COLLEGE AND HOSPITAL, KALITHEERTHALKUPPAM, PUDUCHERRY - 605107, INDIA 3. DR. POOMALAR. G.K, PROFESSOR, OBG, SRI MANAKULA VINAYAGAR MEDICAL COLLEGE AND HOSPITAL, KALITHEERTHALKUPPAM, PUDUCHERRY - 605107, INDIA 4. DR. D. RAJASREE, SENIOR RESIDENT, RADIODIAGNOSIS, SRI MANAKULA VINAYAGAR MEDICAL COLLEGE AND HOSPITAL, KALITHEERTHALKUPPAM, PUDUCHERRY - 605107, INDIA | | |
| DATE OF REGISTRATION | 07/04/2021 | |
| TITLE | AUTOMATIC CHEMICAL DISPENSING SYSTEM WITH FILTER FOR URINE ANALYSIS | |
| PRIORITY NA | | |
| DESIGN NUMBER | 342050-001 |  |
| CLASS | 24-01 | |
| 1.DR. JAWAHAR. K, ASSISTANT PROFESSOR., GENERAL SURGERY, SRI MANAKULA VINAYAGAR MEDICAL COLLEGE AND HOSPITAL, KALITHEERTHALKUPPAM, PUDUCHERRY - 605107, INDIA 2. DR. S. BABU, PROFESSOR., GENERAL SURGERY, SRI MANAKULA VINAYAGAR MEDICAL COLLEGE AND HOSPITAL, KALITHEERTHALKUPPAM, PUDUCHERRY - 605107, INDIA 3. DR. K. SRINIVASAN, PROFESSOR., GENERAL SURGERY, SRI MANAKULA VINAYAGAR MEDICAL COLLEGE AND HOSPITAL, KALITHEERTHALKUPPAM, PUDUCHERRY - 605107, INDIA 4. DR. MAHARAJA. P, ASSOCIATE PROFESSOR., GENERAL SURGERY, SRI MANAKULA VINAYAGAR MEDICAL COLLEGE AND HOSPITAL, KALITHEERTHALKUPPAM, PUDUCHERRY - 605107, INDIA | | |
| DATE OF REGISTRATION | 07/04/2021 | |
| TITLE | DIGITAL SINGLE SLOTTED BLOOD GEL CARD CENTRIFUGE | |
| PRIORITY NA | | |



| | | |
|---|---|---|
| DESIGN NUMBER | 342053-001 |  |
| CLASS | 24-01 | |
| <p>1.DR. M. ANTO, PROFESSOR, GENERAL SURGERY, SRI MANAKULA VINAYAGAR MEDICAL COLLEGE AND HOSPITAL, KALITHEERTHALKUPPAM, PUDUCHERRY - 605107, INDIA 2. DR. G.V. MANOHARAN, PROFESSOR, GENERAL SURGERY, SRI MANAKULA VINAYAGAR MEDICAL COLLEGE AND HOSPITAL, KALITHEERTHALKUPPAM, PUDUCHERRY - 605107, INDIA 3. DR. M. RAJAVEL, ASSOCIATE PROFESSOR, GENERAL SURGERY, SRI MANAKULA VINAYAGAR MEDICAL COLLEGE AND HOSPITAL, KALITHEERTHALKUPPAM, PUDUCHERRY - 605107, INDIA 4. DR. ARULSELVAN. A, ASSISTANT PROFESSOR, GENERAL SURGERY, SRI MANAKULA VINAYAGAR MEDICAL COLLEGE AND HOSPITAL, KALITHEERTHALKUPPAM, PUDUCHERRY - 605107, INDIA</p> | | |
| DATE OF REGISTRATION | 07/04/2021 | |
| TITLE | URINALYSIS SLIDE WASHING AND SLIDE HOLDING TRAY | |
| PRIORITY NA | | |
| DESIGN NUMBER | 342054-001 |  |
| CLASS | 24-01 | |
| <p>1.DR. M. RAJAVEL, ASSOCIATE PROFESSOR, GENERAL SURGERY, SRI MANAKULA VINAYAGAR MEDICAL COLLEGE AND HOSPITAL, KALITHEERTHALKUPPAM, PUDUCHERRY - 605107, INDIA 2. DR. M. ANTO, PROFESSOR, GENERAL SURGERY, SRI MANAKULA VINAYAGAR MEDICAL COLLEGE AND HOSPITAL, KALITHEERTHALKUPPAM, PUDUCHERRY - 605107, INDIA 3. DR. G.V. MANOHARAN, PROFESSOR, GENERAL SURGERY, SRI MANAKULA VINAYAGAR MEDICAL COLLEGE AND HOSPITAL, KALITHEERTHALKUPPAM, PUDUCHERRY - 605107, INDIA 4. DR. ARULSELVAN. A, ASSISTANT PROFESSOR, GENERAL SURGERY, SRI MANAKULA VINAYAGAR MEDICAL COLLEGE AND HOSPITAL, KALITHEERTHALKUPPAM, PUDUCHERRY - 605107, INDIA</p> | | |
| DATE OF REGISTRATION | 07/04/2021 | |
| TITLE | LED LIGHT ILLUMINATING URINE SEDIMENT ANALYSER | |
| PRIORITY NA | | |
| DESIGN NUMBER | 342059-001 |  |
| CLASS | 24-01 | |
| <p>1.DR. SANTHANA KRISHNAN. K, PROFESSOR., ENT, SRI MANAKULA VINAYAGAR MEDICAL COLLEGE AND HOSPITAL, KALITHEERTHALKUPPAM, PUDUCHERRY - 605107, INDIA 2. DR. DILIP CHANDAR. D, ASSOCIATE PROFESSOR., ANESTHESIOLOGY, SRI MANAKULA VINAYAGAR MEDICAL COLLEGE AND HOSPITAL, KALITHEERTHALKUPPAM, PUDUCHERRY - 605107, INDIA 3. DR. POORNIMA S BHAT, ASSISTANT PROFESSOR., ENT, SRI MANAKULA VINAYAGAR MEDICAL COLLEGE AND HOSPITAL, KALITHEERTHALKUPPAM, PUDUCHERRY - 605107, INDIA 4. DR. SRINIVASAN. R, ASSISTANT PROFESSOR., ANESTHESIOLOGY, SRI MANAKULA VINAYAGAR MEDICAL COLLEGE AND HOSPITAL, KALITHEERTHALKUPPAM, PUDUCHERRY - 605107, INDIA</p> | | |
| DATE OF REGISTRATION | 07/04/2021 | |
| TITLE | BLOOD SPECIMEN VOLUME MEASURING DIGITAL DEVICE | |
| PRIORITY NA | | |

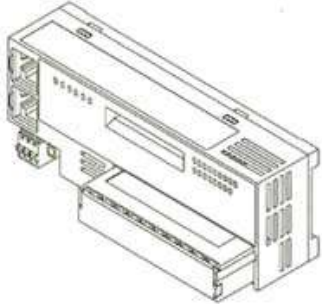
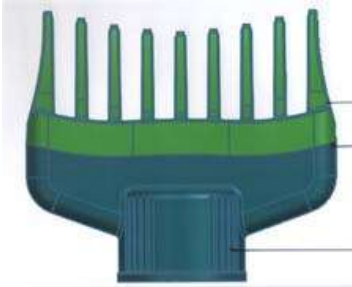

| | | |
|--|--|---|
| DESIGN NUMBER | 342064-001 |  |
| CLASS | 12-16 | |
| 1. PANDIT DEENDAYAL PETROLEUM UNIVERSITY, RAISAN VILLAGE, GANDHINAGAR - 382007, GUJARAT, INDIA 2. DR. ANIRBID SIRCAR, DEAN- RESEARCH AND DEVELOPMENT, PANDIT DEENDAYAL PETROLEUM UNIVERSITY, RAISAN VILLAGE, GANDHINAGAR - 382007, GUJARAT, INDIA 3. DR. KRITI YADAV, RESEARCH ASSOCIATE, CENTER OF EXCELLENCE FOR GEOTHERMAL ENERGY, PANDIT DEENDAYAL PETROLEUM UNIVERSITY, RAISAN VILLAGE, GANDHINAGAR - 382007, GUJARAT, INDIA | | |
| DATE OF REGISTRATION | 07/04/2021 | |
| TITLE | AIRCRAFT WHEEL CHOCK | |
| PRIORITY NA | | |
| DESIGN NUMBER | 342069-001 |  |
| CLASS | 23-01 | |
| 1. DR. MANGANI MANGALAVALLI. S, ASSISTANT PROFESSOR., PHYSIOLOGY, SRI MANAKULA VINAYAGAR MEDICAL COLLEGE AND HOSPITAL, KALITHEERTHALKUPPAM, PUDUCHERRY - 605107, INDIA 2. G. N. ANURADHA, MANAKULA VINAYAGAR INSTITUTE OF TECHNOLOGY, KALITHEERTHALKUPPAM, PUDUCHERRY - 605107, INDIA | | |
| DATE OF REGISTRATION | 07/04/2021 | |
| TITLE | TOUCH FREE WATER DISPENSER FOR URINE SLIDE WASHING | |
| PRIORITY NA | | |
| DESIGN NUMBER | 342071-001 |  |
| CLASS | 07-02 | |
| HAWKINS COOKERS LIMITED, MAKER TOWER F-101, CUFFE PARADE, P.O. BOX NO. 16083, MUMBAI - 400 005, MAHARASHTRA, INDIA | | |
| DATE OF REGISTRATION | 07/04/2021 | |
| TITLE | COOKWARE | |
| PRIORITY NA | | |

| | | |
|---|--|---|
| DESIGN NUMBER | 342124-001 |  |
| CLASS | 24-01 | |
| 1.DR. R. VALLI, PROFESSOR AND R&D COORDINATOR, DEPARTMENT OF ELECTRONICS AND COMMUNICATION ENGINEERING, MANAKULA VINAYAGAR INSTITUTE OF TECHNOLOGY, KALITHEERTHALKUPPAM, PUDUCHERRY - 605107, INDIA 2. DR. S. MALARKKAN, PRINCIPAL, DEPARTMENT OF ELECTRONICS AND COMMUNICATION ENGINEERING, MANAKULA VINAYAGAR INSTITUTE OF TECHNOLOGY, KALITHEERTHALKUPPAM, PUDUCHERRY - 605107, INDIA 3. DR. N POONGUZHALLI, ASSOCIATE PROFESSOR, DEPARTMENT OF COMPUTER SCIENCE ENGINEERING, MANAKULA VINAYAGAR INSTITUTE OF TECHNOLOGY, KALITHEERTHALKUPPAM, PUDUCHERRY - 605107, INDIA 4. V. RAJESH, ASSISTANT PROFESSOR, DEPARTMENT OF ELECTRONICS AND COMMUNICATION ENGINEERING, MANAKULA VINAYAGAR INSTITUTE OF TECHNOLOGY, KALITHEERTHALKUPPAM, PUDUCHERRY - 605107, INDIA | | |
| DATE OF REGISTRATION | 08/04/2021 | |
| TITLE | HOT TOWEL WAX SQUEEZER FOR ORTHO PHYSIOTHERAPY | |
| PRIORITY NA | | |
| DESIGN NUMBER | 342126-002 |  |
| CLASS | 12-16 | |
| P. JAYAKUMAR, RESEARCH FACULTY, IRC – KALASALINGAM ACADEMY OF RESEARCH AND EDUCATION, ANAND NAGAR, KRISHNANKOIL - 626 126, SRIVILLIPUTTUR (VIA), VIRUDUNAGAR DISTRICT TAMILNADU, INDIA | | |
| DATE OF REGISTRATION | 08/04/2021 | |
| TITLE | WATER PROOF CAR COVER WITH ELECTROMAGNETIC STRIP | |
| PRIORITY NA | | |
| DESIGN NUMBER | 335724-001 |  |
| CLASS | 23-01 | |
| 3G-AQUA WATER TREATMENT TECHNOLOGY, 202, FLORAL MORYA GARDEN, NEAR KARNATAKA SCHOOL, KANADIA ROAD, INDORE 452 016, MADHYA PRADESH. | | |
| DATE OF REGISTRATION | 01/12/2020 | |
| TITLE | WATER SOFTENING APPARATUS | |
| PRIORITY NA | | |

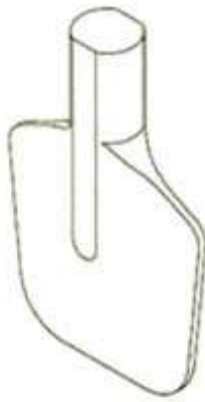

| | | | |
|--|--|----------------|---|
| DESIGN NUMBER | 335838-001 | |  |
| CLASS | 02-01 | | |
| KINSHU JAIN, 4-B, HEEDA KI MORI, GURUDWARA, GALTA ROAD, JAIPUR (RAJ.)- 302003 | | | |
| DATE OF REGISTRATION | 03/12/2020 | | |
| TITLE | NIGHTY WITH ROBE SET | | |
| PRIORITY NA | | | |
| DESIGN NUMBER | 342144-001 | |  |
| CLASS | 10-04 | | |
| 1.SUBASHNI BHOOPATHY, CENTRE FOR OCEAN RESEARCH, SATHYABAMA INSTITUTE OF SCIENCE AND TECHNOLOGY, CHENNAI – 600119, TAMILNADU, INDIA 2. THIRUGNANASAMBANDAM RAJENDRAN, SCIENTIST - B, COL. DR. JEPPIAAR RESEARCH PARK, CENTRE FOR OCEAN RESEARCH, SATHYABAMA INSTITUTE OF SCIENCE AND TECHNOLOGY, CHENNAI - 600119, TAMILNADU, INDIA | | | |
| DATE OF REGISTRATION | 08/04/2021 | | |
| TITLE | AQUARIUM WATER PH AND TEMPERATURE METER WITH DISPLAY | | |
| PRIORITY NA | | | |
| DESIGN NUMBER | 241603 | |  |
| CLASS | 23-01 | | |
| NEOPERL GMBH, A GERMAN COMPANY, OF KLOSTERRUNSSTR-11, 79379 MULLHEIM, GERMANY | | | |
| DATE OF REGISTRATION | 20/12/2011 | | |
| TITLE | BATHROOM OR KITCHEN FAUCET AERATOR | | |
| PRIORITY | | | |
| PRIORITY NUMBER | DATE | COUNTRY | |
| 001282065-0009 | 20/06/2011 | OHIM | |

| | | |
|---|-----------------------|--|
| DESIGN NUMBER | 342265-002 |  |
| CLASS | 13-03 | |
| SAMRAT INDUSTRIES, 1ST FLOOR, GALA NO. 121, DATTATARAY INDUSTRIAL ESTATE, SURVEY NO. 75, VILLAGE WALIV, VASAI EAST, DIST. THANE - 401208, MAHARASHTRA, INDIA | | |
| DATE OF REGISTRATION | 12/04/2021 | |
| TITLE | ELECTRIC SWITCH PLATE | |
| PRIORITY NA | | |
| DESIGN NUMBER | 342272-001 |  |
| CLASS | 14-02 | |
| MITSUBISHI ELECTRIC CORPORATION, 7-3, MARUNOUCHI 2-CHOME, CHIYODA-KU, TOKYO 1008310, JAPAN | | |
| DATE OF REGISTRATION | 12/04/2021 | |
| TITLE | SIGNAL RELAY DEVICE | |
| PRIORITY NA | | |
| DESIGN NUMBER | 342297-001 |  |
| CLASS | 09-07 | |
| TREASURE MOLDERS, PLOT NO. 612, G.I.D.C., ANKLESHWAR, BHARUCH, GUJARAT - 393002, WHOSE PARTNERS ARE (1) SAMIR YOGESH TREASURER, (2) SNEHA TREASURER & (3) YOGESH TREASURER | | |
| DATE OF REGISTRATION | 13/04/2021 | |
| TITLE | BOTTLE CAP | |
| PRIORITY NA | | |



| | | | |
|---|---------------|----------------|--|
| DESIGN NUMBER | 335872-001 | |  |
| CLASS | 02-02 | | |
| JAGDAMBA SAREES PVT. LTD., 2004-2005, 1ST FLOOR, HARIHAR TEXTILE MARKET, RING ROAD, SURAT 395002 (GUJARAT) | | | |
| DATE OF REGISTRATION | 03/12/2020 | | |
| TITLE | SAREES | | |
| PRIORITY NA | | | |
| DESIGN NUMBER | 335876-001 | |  |
| CLASS | 02-01 | | |
| KINSHU JAIN, 4-B, HEEDA KI MORI, GURUDWARA, GALTA ROAD, JAIPUR (RAJ.)- 302003 | | | |
| DATE OF REGISTRATION | 03/12/2020 | | |
| TITLE | NIGHTWEAR SET | | |
| PRIORITY NA | | | |
| DESIGN NUMBER | 335948-001 | |  |
| CLASS | 31-00 | | |
| KEMPISCHE BRIK CENTRALE, BRIXTONLAAN 26 BUS 3E 1930 ZAVENTEM BELGIUM | | | |
| DATE OF REGISTRATION | 05/12/2020 | | |
| TITLE | STIRRER | | |
| PRIORITY | | | |
| PRIORITY NUMBER | DATE | COUNTRY | |
| 007984539-0002 | 05/06/2020 | EUIPO | |

| | | |
|--|-------------------------------------|---|
| DESIGN NUMBER | 335989-002 |  |
| CLASS | 09-01 | |
| OCEANA POSITIVE, NO. 102, 1ST FLOOR, GHMC. NO. 6-3-350, GANGA ESTATES, NAGARJUNA CIRCLE, BESIDES CENTRO, ROAD NO. 1, BANJARA HILLS, HYDERABAD-500034, TELANGANA, INDIA, WHOSE PARTNERS ARE PRIYA NAIDU KARNA AND SATISH NAIDU KARNA | | |
| DATE OF REGISTRATION | 07/12/2020 | |
| TITLE | BOTTLE | |
| PRIORITY NA | | |
| DESIGN NUMBER | 342342-002 |  |
| CLASS | 07-05 | |
| MR. SHAILESHBHAI NARENDRABHAI DOMADIYA, SAKET HEIGHTS TOWER, C-403, V Y O ROAD, OPP. POLICE HEADQUARTER, AMBIKA TOWNSHIP, RAJKOT POSTAL COLONY, RAJKOT-360004, GUJARAT, INDIA | | |
| DATE OF REGISTRATION | 13/04/2021 | |
| TITLE | DRIERS FOR CLOTHES (CLOTHES HORSES) | |
| PRIORITY NA | | |
| DESIGN NUMBER | 342349-001 |  |
| CLASS | 06-04 | |
| BENNY M. ABRAHAM, 46/1169 A, MADAPPATTU ROAD, CHALIKKAVATTOM, KOCHI - 682028, KERALA STATE, TRADING AS M/S EUROMAX INDUSTRIES, | | |
| DATE OF REGISTRATION | 13/04/2021 | |
| TITLE | STORAGE RACK | |
| PRIORITY NA | | |

| | | |
|--|--|---|
| DESIGN NUMBER | 342442-001 |  |
| CLASS | 24-01 | |
| 1.DR. GIRISHA L, ASSOCIATE PROFESSOR, DEPARTMENT OF MECHANICAL ENGINEERING, P.E.S. INSTITUTE OF TECHNOLOGY AND MANAGEMENT, NH 206, SAGAR ROAD, SHIVAMOGGA, KARNATAKA - 577204, INDIA 2. MR. MALTESHKUMAR DESHPANDE, ASSISTANT PROFESSOR, DEPARTMENT OF MECHANICAL ENGINEERING, P.E.S. INSTITUTE OF TECHNOLOGY AND MANAGEMENT, NH 206, SAGAR ROAD, SHIVAMOGGA, KARNATAKA - 577204, INDIA 3. DR. KEERTHI KUMAR N, ASSISTANT PROFESSOR, DEPARTMENT OF MECHANICAL ENGINEERING, BMS INSTITUTE OF TECHNOLOGY AND MANAGEMENT, DODDABALLAPUR MAIN ROAD, AVALAHALLI, YELAHANKA, BANGALORE, KARNATAKA-560064, INDIA 4. MR. RAGHUNANDAN G H, ASSISTANT PROFESSOR, ELECTRONICS AND TELECOMMUNICATION ENGINEERING, BMS INSTITUTE OF TECHNOLOGY AND MANAGEMENT, DODDABALLAPUR MAIN ROAD, AVALAHALLI, YELAHANKA, BANGALORE, KARNATAKA-560064, INDIA , ET AL. | | |
| DATE OF REGISTRATION | 15/04/2021 | |
| TITLE | COST EFFECTIVE VENTILATOR USING CO2 LASER CUTTING MACHINE FOR COVID-19 | |
| PRIORITY NA | | |
| DESIGN NUMBER | 342491-001 |  |
| CLASS | 26-02 | |
| SAI ELECTRICALS, JAIHIND CHOWK, RAMMANDIR ROAD, YAVATMAL 445001, MAHARASHTRA | | |
| DATE OF REGISTRATION | 16/04/2021 | |
| TITLE | HAND LAMP | |
| PRIORITY NA | | |
| DESIGN NUMBER | 342496-001 |  |
| CLASS | 09-01 | |
| NV DISTILLERIES PRIVATE LIMITED, 10TH FLOOR, VANDANA BUILDING 11TH, TOLSTOY MARG, NEW DELHI-110001, INDIA | | |
| DATE OF REGISTRATION | 16/04/2021 | |
| TITLE | BOTTLE | |
| PRIORITY NA | | |



| | | |
|---|-----------------------------|--|
| DESIGN NUMBER | 342496-002 |  |
| CLASS | 09-01 | |
| NV DISTILLERIES PRIVATE LIMITED, 10TH FLOOR, VANDANA BUILDING 11TH, TOLSTOY MARG, NEW DELHI-110001, INDIA | | |
| DATE OF REGISTRATION | 16/04/2021 | |
| TITLE | BOTTLE | |
| PRIORITY NA | | |
| DESIGN NUMBER | 342496-004 |  |
| CLASS | 09-01 | |
| NV DISTILLERIES PRIVATE LIMITED, 10TH FLOOR, VANDANA BUILDING 11TH, TOLSTOY MARG, NEW DELHI-110001, INDIA | | |
| DATE OF REGISTRATION | 16/04/2021 | |
| TITLE | BOTTLE | |
| PRIORITY NA | | |
| DESIGN NUMBER | 342532-001 |  |
| CLASS | 10-05 | |
| 1.NEELABH SAO, KALPATARU, BESIDE SHAHANAI MARRIAGE PALACE, PUSHPAK NAGAR, BHILAI, DISTT. DURG. 490020 2. DR SIPI DUBEY, 288/7, MAITRIKUNJ, BHILAI DISTT. DURG 490006 | | |
| DATE OF REGISTRATION | 19/04/2021 | |
| TITLE | JOINT PAIN ANALYSING DEVICE | |
| PRIORITY NA | | |

| | | |
|---|----------------------------|---|
| DESIGN NUMBER | 342595-001 |  |
| CLASS | 02-02 | |
| ITALIYA JEMISH SHANTIBHAI, MAIN BAZAR, NAVAPARA, NAGDHANIBA, DIS. - BHAVNAGAR - 364050, INDIA | | |
| DATE OF REGISTRATION | 21/04/2021 | |
| TITLE | LADIES GARMENT SET | |
| PRIORITY NA | | |
| DESIGN NUMBER | 342750-003 |  |
| CLASS | 02-02 | |
| BAVISHI UMESHBHAI ARVINDBHAI, A-2-401, INDRA LOK RESIDENCY, LAJAMANI CHOK MOTA VARACHHA, CHORASI, SURAT - 394101, GUJARAT, INDIA | | |
| DATE OF REGISTRATION | 26/04/2021 | |
| TITLE | KURTA PAJAMA DUPATTA (SET) | |
| PRIORITY NA | | |
| DESIGN NUMBER | 342751-003 |  |
| CLASS | 02-05 | |
| BAVISHI UMESHBHAI ARVINDBHAI, A-2-401, INDRA LOK RESIDENCY, LAJAMANI CHOK MOTA VARACHHA, CHORASI, SURAT - 394101, GUJARAT, INDIA | | |
| DATE OF REGISTRATION | 26/04/2021 | |
| TITLE | DUPATTA | |
| PRIORITY NA | | |

| | | | |
|--|--------------|-------------------|---|
| DESIGN NUMBER | 320761-001 | |  |
| CLASS | 14-03 | | |
| SAMSUNG ELECTRONICS CO., LTD., 129, SAMSUNG-RO, YEONGTONG-GU, SUWON-SI, GYEONGGI-DO, 16677, REPUBLIC OF KOREA | | | |
| DATE OF REGISTRATION | 16/08/2019 | | |
| TITLE | MOBILE PHONE | | |
| PRIORITY | | | |
| PRIORITY NUMBER | DATE | COUNTRY | |
| 30-2019-0008063 | 22/02/2019 | REPUBLIC OF KOREA | |
| DESIGN NUMBER | 320774-001 | |  |
| CLASS | 14-03 | | |
| SAMSUNG ELECTRONICS CO., LTD., 129, SAMSUNG-RO, YEONGTONG-GU, SUWON-SI, GYEONGGI-DO, 16677, REPUBLIC OF KOREA | | | |
| DATE OF REGISTRATION | 16/08/2019 | | |
| TITLE | MOBILE PHONE | | |
| PRIORITY | | | |
| PRIORITY NUMBER | DATE | COUNTRY | |
| 30-2019-0008063 | 22/02/2019 | REPUBLIC OF KOREA | |
| DESIGN NUMBER | 320804-001 | |  |
| CLASS | 14-03 | | |
| SAMSUNG ELECTRONICS CO., LTD., 129, SAMSUNG-RO, YEONGTONG-GU, SUWON-SI, GYEONGGI-DO, 16677, REPUBLIC OF KOREA | | | |
| DATE OF REGISTRATION | 17/08/2019 | | |
| TITLE | MOBILE PHONE | | |
| PRIORITY | | | |
| PRIORITY NUMBER | DATE | COUNTRY | |
| 30-2019-0008063 | 22/02/2019 | REPUBLIC OF KOREA | |

| | | |
|--|-----------------------------------|---|
| DESIGN NUMBER | 329734-001 |  |
| CLASS | 31-00 | |
| 1.DR.PUSHPENDRA SINGH, ASSOCIATE PROFESSOR, ELECTRICAL ENGINEERING DEPARTMENT, JK LAKSHSHMIPAT UNIVERSITY, NEAR MAHINDRA SEZ, P.O. 302 026, AJMER ROAD, MAHAPURA, RAJASTHAN-302026 2. KANAK KUMAR, PHD RESEARCH SCHOLAR, DEPARTMENT OF ELECTRONICS ENGINEERING, IIT BHU VARANASI, UTTAR PRADESH-221005 3. DR. KIRTI VERMA, ASSOCIATE PROFESSOR, LAKSHMI NARAIN COLLEGE OF TECHNOLOGY ,H.NO H-118A/66 SHIVAJI NAGAR,BHOPAL, 462016 4. NEERAJ KUMAR, PHD RESEARCH SCHOLAR (SRF),DEPARTMENT OF ELECTRONICS ENGINEERING, IIT (ISM) DHANBAD-626004, JHARKHAND , ET AL. | | |
| DATE OF REGISTRATION | 01/06/2020 | |
| TITLE | SMART CARBONLESS COOKING GASIFIER | |
| PRIORITY NA | | |
| DESIGN NUMBER | 342191-002 |  |
| CLASS | 23-01 | |
| SPRING BIRD POLYTECH, C - 37, ROAD NO. 9, GIDC ODHAV, AHMEDABAD - 382415, GUJARAT - INDIA, WHOSE PROPRIETOR IS PRATIK S. PATEL | | |
| DATE OF REGISTRATION | 09/04/2021 | |
| TITLE | SPRINKLER | |
| PRIORITY NA | | |
| DESIGN NUMBER | 330226-001 |  |
| CLASS | 28-03 | |
| KAMLESH NIRANJAN PATEL, 2 AMRAKUNJ FLATS, SARABHAI SOCIETY GOTRI ROAD, BARODA, GUJARAT -390021 | | |
| DATE OF REGISTRATION | 19/06/2020 | |
| TITLE | RAZOR HEAD | |
| PRIORITY NA | | |

| | | |
|---|--------------|---|
| DESIGN NUMBER | 330341-001 |  |
| CLASS | 07-02 | |
| HAWKINS COOKERS LIMITED, MAKER TOWER F-101, CUFFE PARADE, P.O. BOX NO. 16083, MUMBAI – 400005, MAHARASHTRA, INDIA. | | |
| DATE OF REGISTRATION | 22/06/2020 | |
| TITLE | COOKWARE | |
| PRIORITY NA | | |
| DESIGN NUMBER | 330719-001 |  |
| CLASS | 08-03 | |
| 1. CHITKARA INNOVATION INCUBATOR FOUNDATION, SCO: 160-161, SECTOR -9C, MADHYA MARG, CHANDIGARH- 160009, INDIA. 2. SHALOM AKHAI, H. NO. 758, SECTOR 11, PANCHKULA- PIN CODE 134112, HARYANA, INDIA. 3. PRATEEK SRIVASTAVA, DEPARTMENT OF MECHANICAL ENGINEERING, CHITKARA UNIVERSITY INSTITUTE OF ENGINEERING AND TECHNOLOGY, CHITKARA UNIVERSITY, CHANDIGARH-PATIALA NATIONAL HIGHWAY, RAJPURA, PUNJAB (140401), INDIA. 4. VENKTESH SHARMA, GH – 104 B FLAT 101, SECTOR 20, PANCHKULA, PIN CODE 134116, HARYANA, INDIA. , ET AL. | | |
| DATE OF REGISTRATION | 03/07/2020 | |
| TITLE | HAND HACKSAW | |
| PRIORITY NA | | |
| DESIGN NUMBER | 330639-001 |  |
| CLASS | 02-04 | |
| AQUALITE INDUSTRIES PRIVATE LIMITED, 18B, BLOCK A-1, PASCHIM VIHAR, NEW DELHI-110063, INDIA | | |
| DATE OF REGISTRATION | 02/07/2020 | |
| TITLE | FOOTWEAR | |
| PRIORITY NA | | |

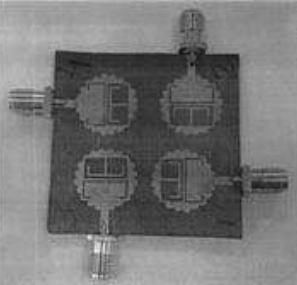
| | | |
|---|------------------------------------|---|
| DESIGN NUMBER | 330644-001 |  |
| CLASS | 02-04 | |
| AQUALITE INDUSTRIES PRIVATE LIMITED, 18B, BLOCK A-1, PASCHIM VIHAR, NEW DELHI-110063, INDIA | | |
| DATE OF REGISTRATION | 02/07/2020 | |
| TITLE | FOOTWEAR | |
| PRIORITY NA | | |
| DESIGN NUMBER | 330665-002 |  |
| CLASS | 10-06 | |
| 1.DR. SIDDARAMA PATIL, PROFESSOR, ELECTRONICS AND COMMUNICATION ENGINEERING DEPARTMENT AND DEAN ACADEMICS POOJYA DIDDAPPA APPA COLLEGE OF ENGINEERING AI-WAN SHAHI ROAD, KALABURAGI 585102 2. DR. JAYASHREE AGARKHED, PROFESSOR, COMPUTER SCIENCE AND ENGINEERING DEPARTMENT, POOJYA DIDDAPPA APPA COLLEGE OF ENGINEERING AI-WAN SHAHI ROAD, KALABURAGI 585102 | | |
| DATE OF REGISTRATION | 02/07/2020 | |
| TITLE | SIGNALING ARM BAND FOR THE ELDERLY | |
| PRIORITY NA | | |
| DESIGN NUMBER | 330680-001 |  |
| CLASS | 14-03 | |
| 1.CHITKARA INNOVATION INCUBATOR FOUNDATION, SCO: 160-161, SECTOR -9C, MADHYA MARG, CHANDIGARH- 160009, INDIA. 2. MANISH SHARMA, CHITKARA UNIVERSITY, CHANDIGARH-PATIALA NATIONAL HIGHWAY, RAJPURA, PUNJAB (140401), INDIA. 3. RAKESH AHUJA, CHITKARA UNIVERSITY, CHANDIGARH-PATIALA NATIONAL HIGHWAY, RAJPURA, PUNJAB (140401), INDIA. | | |
| DATE OF REGISTRATION | 02/07/2020 | |
| TITLE | ANTENNA | |
| PRIORITY NA | | |

| | | |
|--|------------------|--|
| DESIGN NUMBER | 330945-001 |  |
| CLASS | 12-08 | |
| IGOWISE MOBILITY PRIVATE LIMITED, #806, BRIGADE SIGNATURE TOWERS, KATTAMNALLUR GATE, OLD MADRAS RD, BENGALURU -560067, BENGALURU, KARNATAKA 560067, INDIA | | |
| DATE OF REGISTRATION | 10/07/2020 | |
| TITLE | ELECTRIC VEHICLE | |
| PRIORITY NA | | |
| DESIGN NUMBER | 330957-001 |  |
| CLASS | 10-04 | |
| MICRO AND NANO TECHNOLOGIES, IT 2004 RAMCHANDRAPURA, SITAPURA RIICO INDUSTRIAL AREA, JAIPUR, RAJASTHAN-302001, INDIA. | | |
| DATE OF REGISTRATION | 10/07/2020 | |
| TITLE | WEIGHT MACHINE | |
| PRIORITY NA | | |
| DESIGN NUMBER | 330963-001 |  |
| CLASS | 15-05 | |
| SESHA GIRI VILLURI, # 15-22-8, VILLURI PARANDHAMAYYA NAIDU STREET, NIDANAM DODDI, ANAKAPALLE, VISAKHAPATNAM-531002, ANDHRA PRADESH, INDIA | | |
| DATE OF REGISTRATION | 10/07/2020 | |
| TITLE | WASHING MACHINE | |
| PRIORITY NA | | |

| | | | |
|--|--|----------------|---|
| DESIGN NUMBER | 330976-001 | |  |
| CLASS | 24-02 | | |
| EPPENDORF AG, BARKHAUSENWEG 1,22339 HAMBURG, GERMANY. | | | |
| DATE OF REGISTRATION | 11/07/2020 | | |
| TITLE | HAND-OPERATED INSTRUMENTS AND TOOLS FOR LABORATORIES | | |
| PRIORITY | | | |
| PRIORITY NUMBER | DATE | COUNTRY | |
| 402020200257-0002 | 17/01/2020 | GERMANY | |
| DESIGN NUMBER | 330977-001 | |  |
| CLASS | 12-16 | | |
| GREAT WALL MOTOR COMPANY LIMITED, 2266 CHAOYANG SOUTH STREET, BAODING CITY, HEBEI PRO.,P.R.CHINA | | | |
| DATE OF REGISTRATION | 11/07/2020 | | |
| TITLE | VEHICLE GRILLE | | |
| PRIORITY | | | |
| PRIORITY NUMBER | DATE | COUNTRY | |
| 202030023328.1 | 14/01/2020 | CHINA | |
| DESIGN NUMBER | 306542 | |  |
| CLASS | 06-01 | | |
| GODREJ & BOYCE MANUFACTURING COMPANY LTD., PIROJSHANAGAR, VIKHROLI (W), MUMBAI - 400079, INDIA. | | | |
| DATE OF REGISTRATION | 11/06/2018 | | |
| TITLE | SOFA | | |
| PRIORITY NA | | | |